



Guidelines for inspection and servicing  
**Rigid/Drawbar eyes**  
2022

# General information

## General information

The components used to connect a vehicle and trailer are exposed, even during normal use, to very high tensions. Regular service and maintenance is a prerequisite if the drawbar is to function well for the duration of its service life.

The length of the service intervals depend on the type of trailers, the loads, roads and climatic conditions etc. The service should ideally be carried out in conjunction with other inspection of the vehicle, e.g. every 60,000 or 90,000 km.

If daily inspection or safety checks show that the function of the product has been impaired, servicing must be carried out immediately.

If any of the product's wear limits have been exceeded, this is an indication that other parts also require servicing.

Check that all type plates and warning/information labels are legible and have not been painted over, washed off or otherwise damaged. Illegible labels must be replaced and can be ordered from VBG Truck Equipment.

If the drawbar/drawbar eye is damaged due to e.g. jackknifing, or collision, the drawbar/drawbar eye must be replaced.

NB! All equipment must be depressurised and without voltage before servicing is carried out. This means that you must disconnect the supply air and the power to drawbars.

Always follow the vehicle manufacturer's bodybuilding instructions.

## Guidelines for inspection and servicing Drawbars/Drawbar eyes 2022

© VBG GROUP TRUCK EQUIPMENT GMBH

11/2022 - Id. -Nr. 10090792a

The content of this publication may not be reproduced either in full or in part without the prior approval of VBG GROUP TRUCK EQUIPMENT GMBH.

This prohibition is applicable for all forms of reproductions in all types of media, including electronic media.

## Explanation of symbols



### Warning!

Never put your fingers into the coupling mouth as they may be crushed. An open coupling always involves a risk of crushing.



### Severity

3 = STOP to ensure future use.

2 = Rectify as soon as possible, within four weeks.







1 = Rectify when able or during next service. Within no more than one year.

		Torque (Nm)	
Size	Quality	Nut	
M24		300	
M20		20/3040	

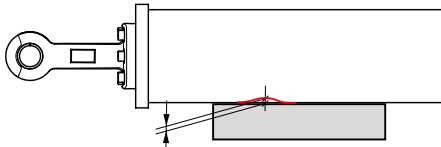

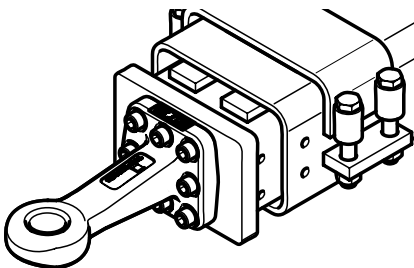

Prescribed tightening torques apply to bolt kits supplied by VBG Group Truck Equipment GMBH.

General information on drawbars and drawbar eyes.....	4
Drawbar ZD, ZFL .....	8
General information on drawbar eyes.....	10

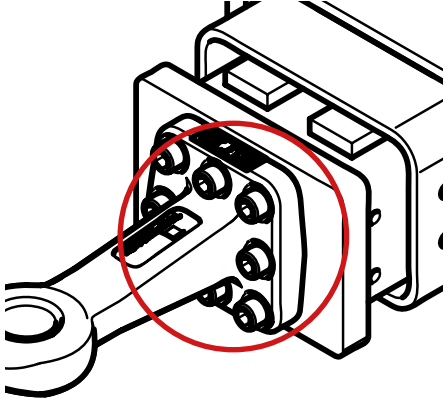
Checkpoint	Symptom	Fault
<p>Typeplate. Drawbar eye. Bushing/bearing eye</p>		
<p>Inner tube, outer tube, bracket</p>	<p>Deformations. The trailer does not “track” the vehicle. Marks from straightening work such as in very heat-affected zones. Welds.</p>	<p>Dents, kinks, twists and bent sheet metal parts such as side members, front and rear sliders, cross member, etc.</p>
<p>Inner tube, outer tube, bracket</p>	<p>Deformations. Cracked, flaking paint. Thin streaks where dust and dirt are not present. Streaks that are rust-coloured. Visible cracks, any rust marks around the crack.</p>	<p>Cracks.</p>
<p>Complete drawbar.</p>	<p>Be aware of noise when driving and if the trailer veers sideways.</p>	<p>Geometric error in inner/outer tube.</p>

<p style="text-align: center;"><b>Inspection method</b></p> <p>Attachment, damage, wear, play.          – Visual check of attachment, damage and wear. The term attachment also covers the eye attachment in the drawbar and the wear ring's attachment in the drawbar eye.          – Rust damage check using tools is performed when corrosion is found.          – Play check of drawbar bearing and extension mechanism. This check is done by applying the trailer brake and rocking the traction vehicle.          – Jackknifing damage/repairs/welds.          – Wear, eyes/bushings.</p>	<p style="text-align: center;"><b>Requirements, wear limits, etc.</b></p>	<p style="text-align: center;"><b>Instructions for rectification</b></p>
<p>Check that none of the parts are deformed.            Deformation may arise in connection with jackknifing, reversing or other external influences.</p>	<p>Generally, no deformations are permitted. Deviation from theoretical surface/shape greater than the specified dimensions is considered to be a deformation. No welding or warping is permitted.            Deviation/length            5 mm/1,000 mm            3 mm/150 mm</p> 	<p>            ① ② ③            ②            In the event of deformation, warping or welds, visit the workshop and replace the damaged parts.            When the components have been dismantled, they must be re-tightened after driving 2,500 km.</p>
<p>Check that none of the parts are cracked. The greatest risk of cracking is close to bend radii, welds and hole edges.</p> 	<p>No cracks are permitted.            No welding or other repairs are permitted</p>	<p>            ① ② ③            ③            In the event of cracking, stop driving and immediately visit a workshop, replace damaged parts.            After replacing damaged parts, tightening takes place after driving 2,500 km.</p>
<p>Measure if there is play between the tubes or the tubes are bended.</p>	<p>No play between the tubes is allowed.</p> 	<p>            ① ② ③            ①            Replace any defective materials and adjust.            After any replacement of damaged parts and adjustment of the geometry, retightening must be performed after driving 2,500 km.            Use the installation instructions for any adjustment.</p>

Checkpoint	Symptom	Fault
<p>Bolted joint.</p>	<p>Scuff marks around bolted joints. Rust around bolt heads/nuts. Squeaking/clicking sound.</p> 	<p>Loose or missing bolts.</p>
<p>Legs, rear member, cross member.</p>	<p>The surface treatment is flaking/chipped. Rusty water flows out from cavities/ partially closed cavities. Loose rust flakes/"soft" material/porosity in the base metal.</p>	<p>Corrosion. "Pitting".</p>
<p>Complete drawbar.</p>	<p>The surface treatment is flaking/chipped. Rusty water flows out from cavities/ partially closed cavities.</p>	<p>Corrosion. Surface rust.</p>

<p style="text-align: center;"><b>Inspection method</b></p> <p>Be aware of banging/clicking sounds or jolts when driving with a trailer.  Check whether rust has formed around the bolt heads and around holes where any bolts have been.  Check to see if there has been any movement in the bolted joints.  Check whether any rotation occurs during testtightening to the prescribed tightening torque in accordance with the table on page 2.</p>	<p style="text-align: center;"><b>Requirements, wear limits, etc.</b></p> <p>No movement is permitted in the bolted joint and there should be no rotation during test-tightening to the prescribed tightening torque.  Prescribed tightening torques apply to bolt kits supplied by VBG Group Truck Equipment GMBH.</p>	<p style="text-align: center;"><b>Instructions for rectification</b></p> <p> In the event of movement in the bolted joint, stop driving and visit a workshop immediately. Dismantle/check constituent parts and replace any that are damaged.</p> <p>① ② ③</p> <p>③</p> <p>② If there is too low a tightening torque, visit a workshop. Dismantle/check constituent parts and replace any that are damaged.  When the components have been dismantled, they must be re-tightened after driving 2,500 km.  Examples of damage.  – Deformed holes  – Damaged threads  – Scuff marks on bolts  – Fretting damage</p>
<p>Check regularly that there is no corrosion damage such as “pitting”. Take particular note of cavities and partially enclosed areas etc.</p>  <p>Side member that has rusted through</p>	<p>“Pitting” should not occur; particular attention should be paid to the inside of cavities and partially enclosed areas.</p>	<p> In the event of pitting, stop driving and immediately visit a workshop.</p> <p>① ② ③ In the event of pitting, damaged parts must be replaced. Welding is not permitted.</p> <p>③</p>
<p>Take particular note of cavities and partially enclosed areas, etc.</p>	<p>Surface rust or red rust must be dealt with urgently.</p>	<p> Remove external rust using a blast-cleaner or a steel brush, and then reapply corrosion protection.</p> <p>① ② ③</p> <p>①</p>

<b>Checkpoint</b>	<b>Symptom</b>	<b>Fault</b>
Legs and cross members - ZD	Paint chipped/cracked or deformed sections.	Reduced durability due to the drawbar eye, side member, front slider or other part being deformed/curved/dented/kinked or having cracks.
Bolted joint - ZFL	Discolouration of bolted joints, marks from micro-movements (no dirt or dust around the overlap plates, bolt heads, etc.) or larger scuff marks.	Banging/clicking sounds while driving due to loose or missing bolts.



### Inspection method

No deformation or cracks are allowed. Deviation from theoretical surface/shape greater than the specified dimensions is considered to be a deformation. Check whether there are any welds or warping. Check regularly or if you suspect any abnormal stress may have affected the drawbar that there is no deformation or cracking.

### Requirements, wear limits, etc.

No deformation or cracks are allowed. Deviation from the theoretical surface/shape greater than the specified dimensions is considered to be a deformation. Check whether there are any welds or warping. Check regularly or if you suspect any abnormal stress may have affected that the drawbar, that there is no distortion or cracking.

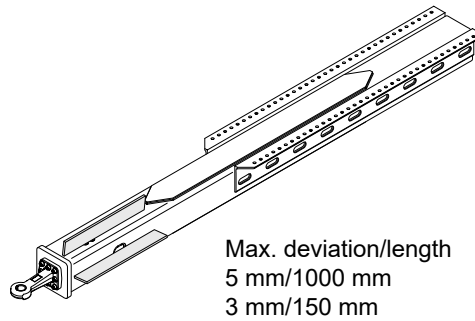

### Instructions for rectification



In the event of cracking, stop driving and immediately visit a workshop, replace damaged parts.

③

②

In the event of deformation, warping or welds, visit the workshop and replace the damaged parts.

Be aware of rust around bolt heads as well as holes where there have previously been bolts. Check to see if there has been any movement in the bolted joints. Check whether any rotation occurs when tightened to the prescribed tightening torque according to the table (see section Drawbars, General information) for M8, M16 (only in combination Cross Member), M20.

No movement is allowed and there should be no rotation when test tightened to the prescribed torque.

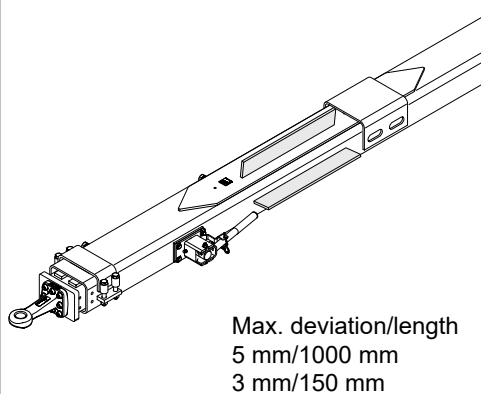

In the event of any movement or insufficient tightening torque, visit a workshop, disassemble and inspect the parts.

②

③

If there are any damaged parts, these must be replaced. When the components have been dismantled, they must be re-tightened after driving 2,500 km.

Examples of damage:

- Deformed holes
- Damaged threads
- Cut marks on bolts
- Fretting damage

Checkpoint	Symptom	Fault
Bolted joint.	Noise, rattling, clicking, scuff marks, absence of dirt/dust around bolt heads and overlap joints, discolouration of rust-coloured water.	Loose or missing bolts/nuts.
Bushing/wear ring.	Connection and/or disconnection problems. Bushing/wear ring axially displaced. The wear ring is not level with the eye.	Loose or damaged bushing/wear ring.
Bushing/wear ring/drawbar eye.	The trailer "jolts" if the road is uneven. Rattling/noise.	Worn bushing/wear ring/drawbar eye.
Bushing/wear ring/drawbar eye.	Be aware of whether the coupling triggers during connection and disconnection, and of noise when driving. Check the height dimension of the eye on the most worn surface.	Drawbar eye/wear ring vertically very worn or pitting in the supporting surfaces.

### Inspection method

Be aware of popping/clicking sounds or jerks when driving with a trailer.  
Be aware of rust around bolt heads as well as holes where there have previously been bolts.  
Check to see whether there has been any movement in the bolted joint.  
Check whether there is any rotation when test-tightened to the prescribed tightening torque.

### Requirements, wear limits, etc.

No movement between parts is permitted and there should be no rotation during test tightening to the prescribed tightening torque. All bolts must be fitted.

### Instructions for rectification



In the event of movement in the bolted joint, stop driving and visit a workshop immediately. Dismantle/check constituent parts and replace any that are damaged.

③

②

If there is too low a tightening torque, visit a workshop. Dismantle/check constituent parts and replace any that are damaged.  
When the components have been dismantled, they must be re-tightened after driving 2,500 km.

Check whether the drawbar is difficult to connect or disconnect.  
Check whether the bushing in the eye is loose by tapping lightly with a hammer on the bushing/wear ring.

The bushing must be secure and in the correct position. There should be no movement.



In the event of a loose wear ring/bushing, visit the workshop to replace the damaged material

②

Measure the bushing's max. diameter D.

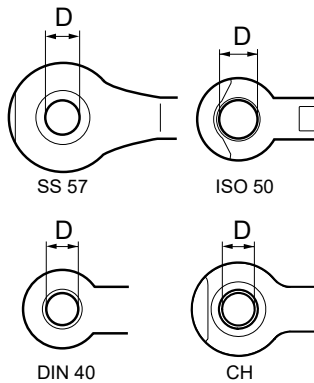

The wear limits for the bushing/wear ring in the drawbar eye are indicated in table.

Type	Max. D (mm)
SS 57	59.5
ISO 50	52
DIN 40	42
CH	42



Replace the wear ring/bushing no later than when max. D has been reached.

②

**NB:** Welding is prohibited.

Check whether the coupling triggers during connection and disconnection, and whether rattling and noise is heard during driving.  
Measure the eye's height dimension T on the most worn surface.

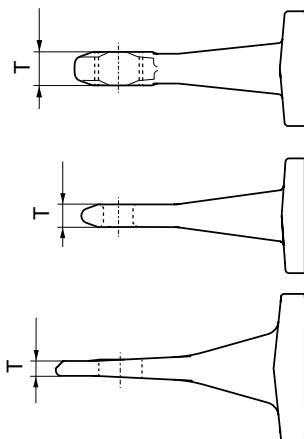

Each drawbar eye's minimum dimension must be achieved.

Type	Min. T (mm)
SS 57	19
NATO	37
ISO 50	42.5
DIN 40	28
CH	38



Replace the drawbar eye if it is thinner than specified dimension T.

②

**NB:** Welding is prohibited

Checkpoint	Symptom	Fault
<p>The drawbar eye's outer geometry.</p>	<p>Difficult to connect.</p>	<p>Worn down outer radius.</p>
<p>The drawbar eye's outer geometry.</p>	<p>Marks from jackknifing on endplates, drawbar, etc.                      Marks from the tipper body, top of the drawbar.                      The drawbar eye is not sitting symmetrically in the drawbar.</p>	<p>Bent drawbar eye due to overloading.</p>
<p>The drawbar eye and its attachment.</p>	<p>Rust residue around a possible crack.                      Cracked paint.                      Other damage in connection with jackknifing.</p>	<p>Cracks in the drawbar eye and in connection with the drawbar eye attachment in the front slider.</p>

### Inspection method

Measure the outer radius as shown in the figure.

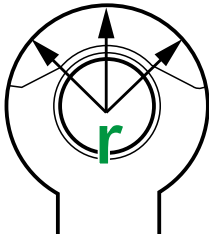

### Requirements, wear limits, etc.

Minimum radius R according to the table.

Type	Min. radius (mm)
SS 57	90
ISO 50	55
DIN 40	48
CH	55

### Instructions for rectification



Replace the drawbar eye if the measured R is less than the specified dimension in the table "Min. Radius".

①

**NB:** Welding is prohibited.

Check whether the drawbar eye is bent vertically and/or laterally.  
Check that the welding and bolted joints are free of cracks.  
Check that the flange/shank of the eye are free of cracks. Measure dimensions A and C and D on the drawbar eye/drawbar's centre line; see picture.

Assessment, no cracks are permitted.

A ≤ 2 mm  
B, C ≤ 2 mm

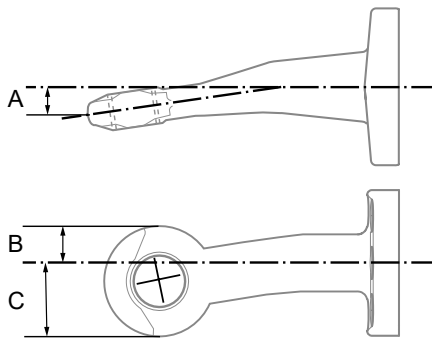

In the event of a bent/overloaded eye, stop driving and immediately visit a workshop, replace damaged parts.

③

If the drawbar eyes are bolted, the bolted joint must be checked and the bolts replaced.

When the components have been dismantled, they must be re-tightened after driving 2,500 km.

**NB!** Warping a drawbar eye is strictly forbidden.

Also check for any cracks in the geometry adjacent to the drawbar eye, both before and after cleaning.  
If you suspect that there is a crack, investigate using liquid penetrant.

No cracks are permitted.



In the event of cracking, stop driving and immediately visit a workshop, replace damaged parts.

③

**NB:** Welding is prohibited.

Checkpoint	Symptom	Fault
<p>Contact surfaces flange/mounting plate, bolts for screwed flange eyes 40/50/57</p>	<p>Some movement between the flange and the drawbar's mounting plate. Marks from jackknifing.</p>	<p>Loose or missing bolts due to overload.</p>
<p>Contact surfaces flange/mounting plate, bolts for Screwed flange eyes 40/50/57</p>	<p>Regular re-tightening required. Some bolts worn out/defective. Absence of dirt/dust in the bridge between the flange and mounting plate, and discolouration of rust-coloured water may occur.</p>	<p>Loose or missing bolts due to mounting plate that is not level.</p>

### Inspection method

Check to see if there has been any movement in the bolted joints. Check whether any rotation occurs when test-tightened to the prescribed tightening torque. Check whether there are marks from jackknifing.

Size	Quality	Torque (Nm)
57 mm	12.9 with Nord-lock	390
50 mm	10.9	240
40 mm	8.8	210

### Requirements, wear limits, etc.

No movement is permitted and there should be no rotation during test-tightening to the prescribed tightening torque. All bolts must be fitted.

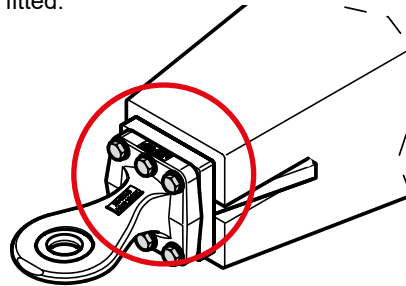

### Instructions for rectification



In the event of movement in the bolted joint, stop driving and immediately visit a workshop, dismantle/check constituent parts and replace any damaged components.

3

2

In the event of an insufficient tightening torque, visit a workshop, dismantle/check the constituent parts and replace damaged components.

New bolts should always be fitted when the eye has been dismantled.

When the components have been dismantled, they must be re-tightened after driving 2,500 km.

Check whether there has been any movement in the bolted joint and/or between the flange and the mounting plate.

Check whether any rotation occurs when test-tightened to the prescribed tightening torque. Check that the drawbar eye's flange surface sits firmly against the drawbar's connection surface.

Size	Quality	Torque (Nm)
57 mm	12.9 with Nord-Lock	390
50 mm	10.9	240
40 mm	8.8	210

The bolted joint must not lose its tension. The connection surfaces of the flange drawbar eye and the drawbar's mounting plate must lie completely flush against each other without gaps.

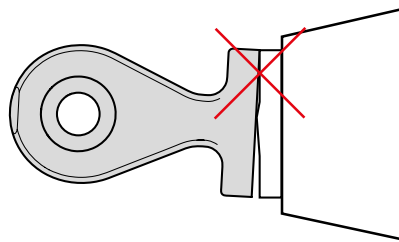

In the event of repeated wear and tear in bolted joints resulting in insufficient tightening torques, visit a workshop, dismantle/check the components and replace any that are damaged.

3

The drawbar's connection surfaces must be levelled if required, flatness requirement = 0.5. New bolts should always be fitted when the drawbar eye has been dismantled.

When the flange eye has been dismantled, it must be re-tightened after driving 2,500 km.



Produced in a certified company

**VBG GROUP TRUCK EQUIPMENT GMBH** · Girmesgath 5 · D-47803 Krefeld  
[www.ringfeder-rf.com](http://www.ringfeder-rf.com)